

# DomusLift®

## VANO IN MURATURA

Misure nette tra  
i piombi con pareti finite.

## MASONRY HOISTWAY

Net dimensions between  
plumb lines with finished  
walls.

## AUFZUG IM MAUERSCHACHT

Nettomaße zwischen  
den Loten von fertigen  
Wänden.

## GAINES EN MAÇONNERIE

Dimensions nettes  
à l'aplomb du point  
le plus étroit de la gaine,  
avec parois finies.



**IGV S.p.A.**

via G. Di Vittorio, 21  
20060 Vignate  
Milan, Italy

Phone +39.02.951271  
Fax +39.02.9560423

www.domuslift.com  
www.igvlift.com  
igvmail@igvlift.com

### [DL-1C]

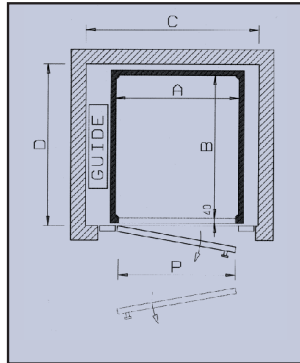

	1C/1	1C/2	1C/3	1C/4	1C/5	1C/6	
<b>A</b>	800	800	800	1000	1000	1000	<b>Cabina / Car Kabine / Cabine</b>
<b>B</b>	800	1000	1300	1300	1000	800	
<b>C</b>	1200	1200	1200	1400	1400	1400	<b>Vano / Shaft Schacht / Gaine</b>
<b>D</b>	950	1150	1450	1450	1150	950	
<b>P</b>	750	750	750	950	950	950	<b>Porta / Door / Tür / Porte</b>
<b>Kg</b>	250	250	250	250	250	250	<b>Portata / Load Tragkraft / Charge</b>

### [DL-1L]

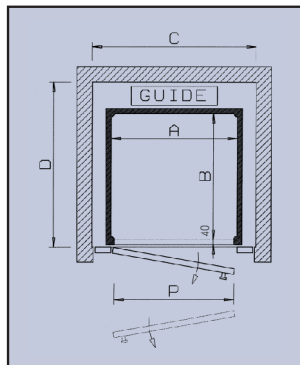

	1L/1	1L/2	1L/3	1L/4	1L/5	1L/6	
<b>A</b>	800	1000	1300	1300	1000	800	<b>Cabina / Car Kabine / Cabine</b>
<b>B</b>	800	800	800	1000	1000	1000	
<b>C</b>	1100	1300	1600	1600	1300	1100	<b>Vano / Shaft Schacht / Gaine</b>
<b>D</b>	1110	1110	1110	1310	1310	1310	
<b>P</b>	750	950	950	950	950	750	<b>Porta / Door / Tür / Porte</b>
<b>Kg</b>	250	250	250	250	250	250	<b>Portata / Load Tragkraft / Charge</b>

### [DL-2A]

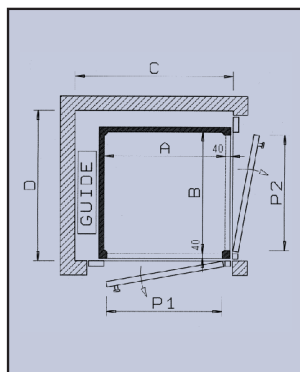

	2A/1	2A/2	2A/3	2A/4	2A/5	2A/6	
<b>A</b>	800	800	800	1000	1000	1000	<b>Cabina / Car Kabine / Cabine</b>
<b>B</b>	800	1000	1300	1300	1000	800	
<b>C</b>	1110	1110	1110	1310	1310	1310	<b>Vano / Shaft Schacht / Gaine</b>
<b>D</b>	1000	1200	1500	1500	1200	1000	
<b>P1</b>	750	750	750	950	950	950	<b>Porta / Door / Tür / Porte</b>
<b>P2</b>	750	950	950	950	950	750	<b>Porta / Door / Tür / Porte</b>
<b>Kg</b>	250	250	250	250	250	250	<b>Portata / Load Tragkraft / Charge</b>

### [DL-2P]

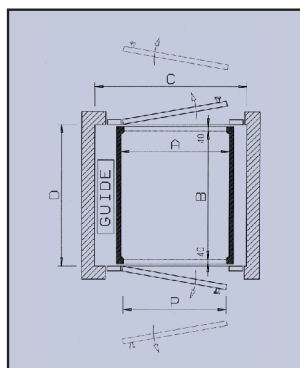

	2P/1	2P/2	2P/3	2P/4	2P/5	2P/6	
<b>A</b>	800	800	800	1000	1000	1000	<b>Cabina / Car Kabine / Cabine</b>
<b>B</b>	800	1000	1300	1300	1000	800	
<b>C</b>	1200	1200	1200	1400	1400	1400	<b>Vano / Shaft Schacht / Gaine</b>
<b>D</b>	920	1120	1420	1420	1120	920	
<b>P</b>	750	750	750	950	950	950	<b>Porta / Door / Tür / Porte</b>
<b>Kg</b>	250	250	250	250	250	250	<b>Portata / Load Tragkraft / Charge</b>